

POWER SUPPLY INSTALLATION & ADJUSTMENT INSTRUCTIONS

For Power Supply Models:

600N, 2200N-A, 2200N-B, 12KN-A, 12KN-B, 12KN -C, 12KN-D

Use Exclusively with FLATLITE® Electroluminescent
Lamps.

! IMPORTANT SAFEGUARDS !

When using electrical equipment, basic safety precautions should always be followed including the following:

- This product must be installed and serviced by electrical contractors familiar with the instructions in this manual and local building codes.
- FLATLITE® Lamp is an electrical appliance operating at up to 280Vac.
- Do not cut or pierce without proper tools and training.
- Never power the unit from a dimmable AC source.
- Never for use in or under water.
- Never install in an accessible area without a protective cover to prevent access.
- Do not install against an ungrounded metal surface.
- Always install in accordance with all applicable electrical codes.
- Always disconnect power from the FLATLITE® system before servicing.
- Equipment must be mounted securely in locations and at heights where it will not be readily subjected to tampering by unauthorized personnel.
- Use of any components not supplied with the FLATLITE® system or the modification of the components supplied may cause an unsafe condition.
- Do not use this equipment for other than its intended purpose
- This equipment is approved and rated for connection of lamps as specified in the system design section. Never exceed the Total or Minimum Load Rating of any power supply.

SAVE THESE INSTRUCTIONS

E-Lite Technologies, Inc. Power Supply Instruction Manual - Page 1 of 4

MAKING ADJUSTMENTS

Tools Needed:

- Phillips head screw driver
- Nonconductive blade adjustment tool
- Voltmeter capable of reading up to 400VAC RMS
- Installed Lamp size (in square inches)
- Needle-nose pliers

1. Completely disconnect Power Supply from any power source
2. If any of the optional CMD modules will be used, leave it disconnected until the Power Supply has been fully adjusted.
- 3a. Models 600N, 2200N-A, B: Remove the cover from the Power Supply and place the supply base so that the components inside are accessible and the choke(s) are to the right.
- 3b. Models 12KN-A,B,C and D: Remove the access port cover from the top of the Power Supply and place the supply so that the opening is toward you and to the right.
4. Confirm that the input voltage select jumper is placed correctly for your operating voltage 120 or 240VAC (See Figure 1, 2 or 3 for jumper location). Refer to the marking on the Printed Circuit Board (PCB). The jumper tab should connect the front two pins for 240VAC and the back two pins for 120VAC. (Disregard this step for Models 12KN-A,B,C,D - voltage adjusts automatically).
5. Next, match the Power Supply to the lamp size by connecting the chokes appropriately (see specifics in Figure 1, 2, or 3. Note: 2200N-B requires no choke setup, and chokes on 12KN models are factory set).
6. Locate the output "VOLTAGE ADJ" (white pot) and limit-adjust "VOLTAGE LIMITING" (blue pot) potentiometers. See Figure 1, 2 or 3 for locations. When adjusting these pots use a NON CONDUCTIVE TOOL.
7. The blue limit pot is preset at the factory and is locked with glue. Set up instructions for this blue limit pot are included in case the glue has been removed or specific instructions to adjust the pot are given from the factory. Turn the white pot all the way counter clockwise and the blue limit pot all the way clockwise.



8. Connect the voltmeter to the output of the Power Supply. This can be done by inserting the probes into the back of the lamp Molex connector or attaching it to the connection points of the distribution wire (12KN models), prior to connection points being insulated.

NOTE: All adjustments must be made with the lamp connected to the Power Supply. The Power Supply must be adjusted to TOTAL area of all lamp being connected to an individual Power Supply. If connecting multiple lamps, all lamps must be wired in parallel.

9. Turn on the Power Supply, the lamp should be dimly lit, the green "Power On" LED will be lit and the voltage should read less than 280VAC.

CAUTION: USE EXTREME CARE WHEN MAKING ADJUSTMENTS WITH POWER ON AND COVER OFF.

10. Adjust the voltage output and voltage limit as follows:

- Turn the white pot all the way clockwise, watching the voltmeter. The output should stay below 320VAC. If it does not, discontinue setup and check that the Power Supply is properly sized to the lamp.
- Turn the blue pot counterclockwise until the meter reads 330VAC.
- Turn the white output counterclockwise to the desired voltage setting, not to exceed 280VAC.
- Allow system to stabilize for five minutes and reset the white pot to the desired voltage or the 280VAC limit. **NOTE:** *At 280VAC the lamp is operating at its brightest setting. To reduce brightness, adjusting the output lower (counterclockwise) until brilliance matches your requirements will increase the life of the lamp and provide for further level of compensation.*
- Turn off power and replace the cover or port access cover.

11. At this point any CMD module can be attached and set as desired.

12. All Models 600N, 2200N-A, B, and 12KN-A,B,C,D have ground fault protection capability. To test this, press the red button and the lamp will turn off. To restart the power supply, switch the unit OFF and the ON again.

TROUBLESHOOTING

PROBLEM: LAMP DOES NOT LIGHT

1. Check that Power Supply is plugged into working outlet.
2. Check that Power Supply switch is "ON".
3. Check the fuses.
4. Check output - check that Power Supply has been properly adjusted for the lamp load (see Adjustment instructions, page 2).
5. If 2200N-A or B, check that the terminals mounted on E-16 and E-17 are not touching each other or any other components on the Printed Circuit Board.
6. Check that the Lamp connection(s) to the Power Supply is (are) well made.
7. Check that the Lamp is wired correctly:
 1. Turn off the power supply
 2. Unplug the Lamp from the Power Supply
 3. Measure across the leads with a digital multimeter to check:
 - a. Continuity-if continuity, there is a short in the wiring
 - b. Capacitance-If no capacitance, there is an open circuit in the wiring

The problem with wiring may be in the lamp crimp attachment or in the distribution wiring. Disconnect lamp from distribution wiring to troubleshoot.

PROBLEM: LAMP BLINKS OR FLASHES

1. Check that the Power Supply has been set to the proper input voltage.
2. Check that the power supply has been adjusted for the correct lamp load.

PROBLEM: LAMP IS DIM

1. Check that the Power Supply has been properly adjusted for the lamp load (see Adjustment instructions, page 2).
2. If 2200N-A or B, check that the terminals mounted on E-16 and E-17 are not touching each other or any other components on the Printed Circuit Board.
3. Check if the Lamp has been operating past its useful life.
4. Call E-Lite for Technical Assistance.

PROBLEM: POWER SUPPLY ADJUSTMENTS OPERATE REVERSE FROM NORMAL

1. Check that the Lamp is within the range of the Power Supply as set.
2. Replace Power Supply with properly sized model.

PROBLEM: THE 280VAC OPERATING VOLTAGE CANNOT BE REACHED

1. Check that the Power Supply has been set to the proper input voltage (does not apply to 12KN-A, B, C, or D).
2. Check that the Lamp is within the range of the Power Supply as set.
3. Check that the Lamp connection(s) to the Power Supply is (are) well made.
4. If 2200N-A or B, check that the terminals mounted on E-16 and E-17 are not touching each other or any other components on the Printed Circuit Board.
5. Replace Power Supply with properly sized model.

PROBLEM: POWER SUPPLY OPERATED INTERMITTENTLY

1. Check that the Power Supply is not overheated. Relocate the Power Supply to a cooler area or provide ventilation.

NOTE: *The Power Supply has a Thermal Protection Circuit that protects the components when the internal temperature exceeds a preset level.*



ALL DRAWINGS TOP VIEW (NOT TO SCALE)

600N - figure 1

For each given lamp range, set the jumpers as follows:

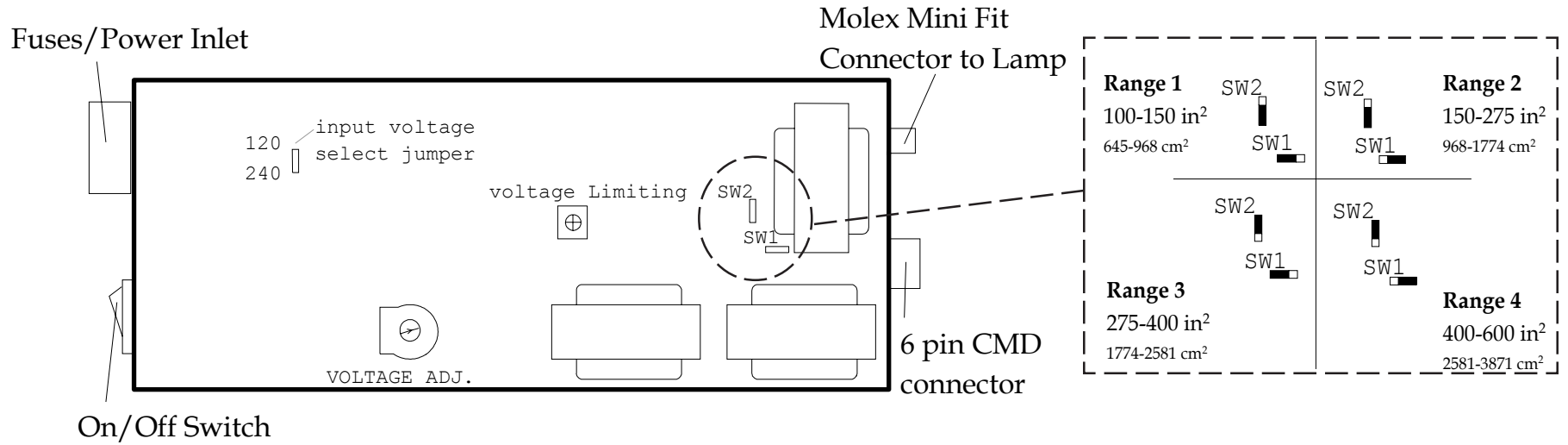

2200N-A & 2200N-B - figure 2

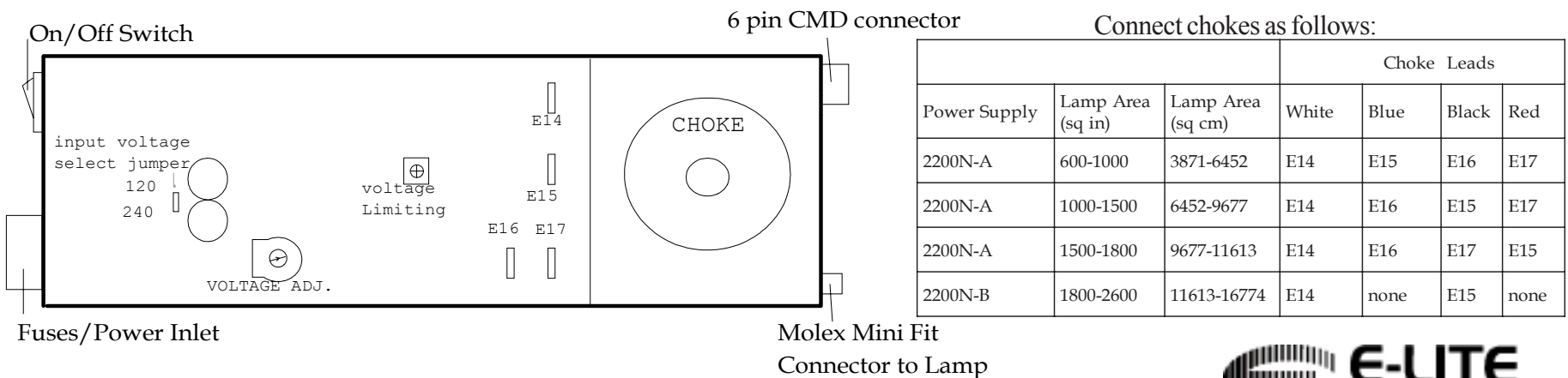

12KN-A, 12KN-B, 12KN-C, 12KN-D - figure 3

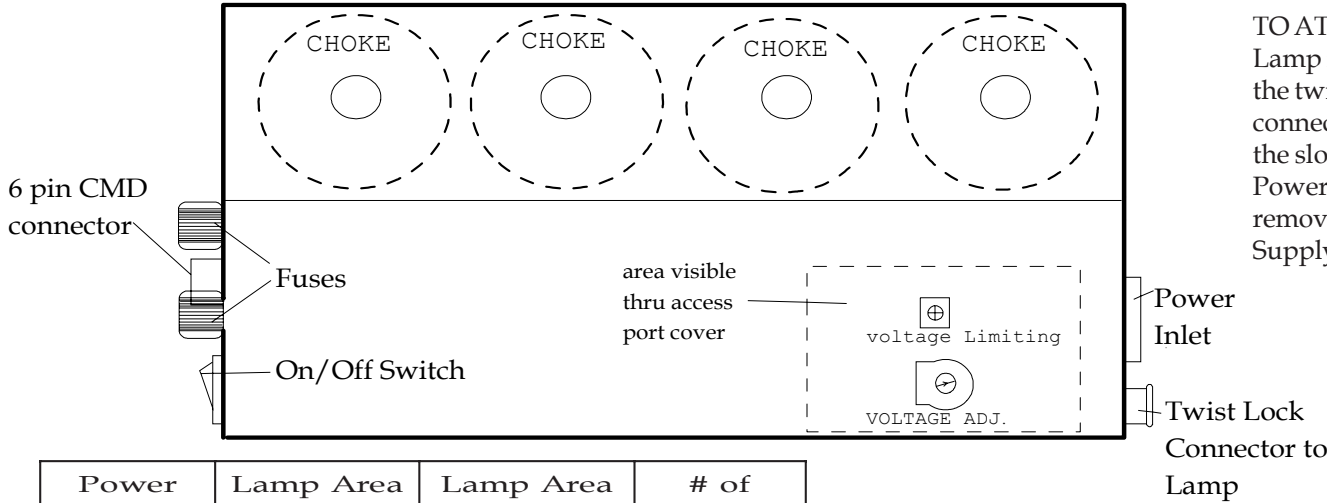

TO ATTACH LAMP:

Lamp is connected to the Power Supply using the twist lock connector provided. To attach connector, align guide rib in plastic cap with the slot on the base, slide out sleeve toward Power Supply and twist clockwise. To remove, push outer sleeve toward Power Supply and twist counter clockwise

Power Supply	Lamp Area (sq in)	Lamp Area (sq cm)	# of chokes
12KN-A	2600-3500	16774-22581	1
12KN-B	3100-5300	20000-34194	2
12KN-C	4800-8000	30968-51613	3
12KN-D	7800-12500	50323-80645	4

To determine how many chokes are on a given power supply, count the number of large bolts on the bottom of the power supply.

IMPORTANT INFO FOR OUTDOOR APPLICATIONS

Sunlight (UV) and ambient temperature affect the electrical characteristics of FLATLITE. Output voltage will vary depending on these factors. Thus setting your output voltage during the day will cause the lamp to have a different voltage at night. Since most outdoor FLATLITE applications are meant for a nighttime operation, it is **strongly recommended that the power supply be adjusted at night.**

(Please note: the safety of the system is not compromised due to the compensating features of the power supplies.)

If night time adjustment is not possible, we have provided a chart of equivalents. This chart shows what output voltage to set the power supply to under a variety of

conditions. For example, if 260VAC is the desired night time setting, if it is being adjusted during a sunny, clear day at an ambient temperature of 60°F (16°C), it must be adjusted to 75VAC. Because the voltages in the chart are only approximate settings, it is strongly recommended that the final tuning of the system be performed during normal system operation times.

A lamp voltage of 280VAC is the maximum allowable nighttime setting, which in turn yields the optimum balance between maximum brightness and lamp life. However many nighttime applications require less brightness to achieve the desired effect as FLATLITE Lamp is a field source of light, rather than a point source of light. There are many variables which effect the perceived brightness of the FLATLITE Lamp in outdoor installations, including the ambient lighting from other buildings, streetlights, etc. Further, when lowering the lamp brightness, the life of the lamp is extended. For best results adjust the lamp after full darkness, taking care not to exceed 280VAC.

conditions	<40°F (<5°C)	40°F<T<80°F (5°C<T<27°C)	>80°F (>27°C)
clear, sunny, daylight	95 VAC	75VAC	55VAC
cloudy daylight	120 VAC	100VAC	80VAC
nighttime	280VAC MAX*	260VAC*	240VAC*

* or to desired brightness but not exceeding 280VAC

